



Suspension Child Carrier



User needs to check whether there are any laws specific to the carrying of children in seats attached to cycles that apply in the locality in which the seat is used.

The proper size and adjustment of bicycle for the rider should be verified in the information supplied with the bicycle, or obtain information from the manufacturer or supplier of the bicycle.

It is recommended a professional bicycle shop assemble and install the BabySeat II to your bike.

It is imperative that you read this owner's manual prior to installation.

Max Weight: 48.5 lb / 22 kg (For the EU Community, meets EN-14344 Class A22 regulations)

40 lb / 18 kg (For USA, meets ASTM F1625 regulations)

TOOLS REQUIRED FOR ASSEMBLY: 5mm Allen Key

Table of Contents

Getting To Know Your Topeak BabySeat	4
Mounting Rack To Bicycle	6
Mounting BabySeat To Rack Surface	8
Securing BabySeat To SeatPost	9
Opening Grab Bar	10
Adjusting Height Of Footrests	11
Fitting Your Child In BabySeat	12
Release Seat Pad	13
Caution Notes	14

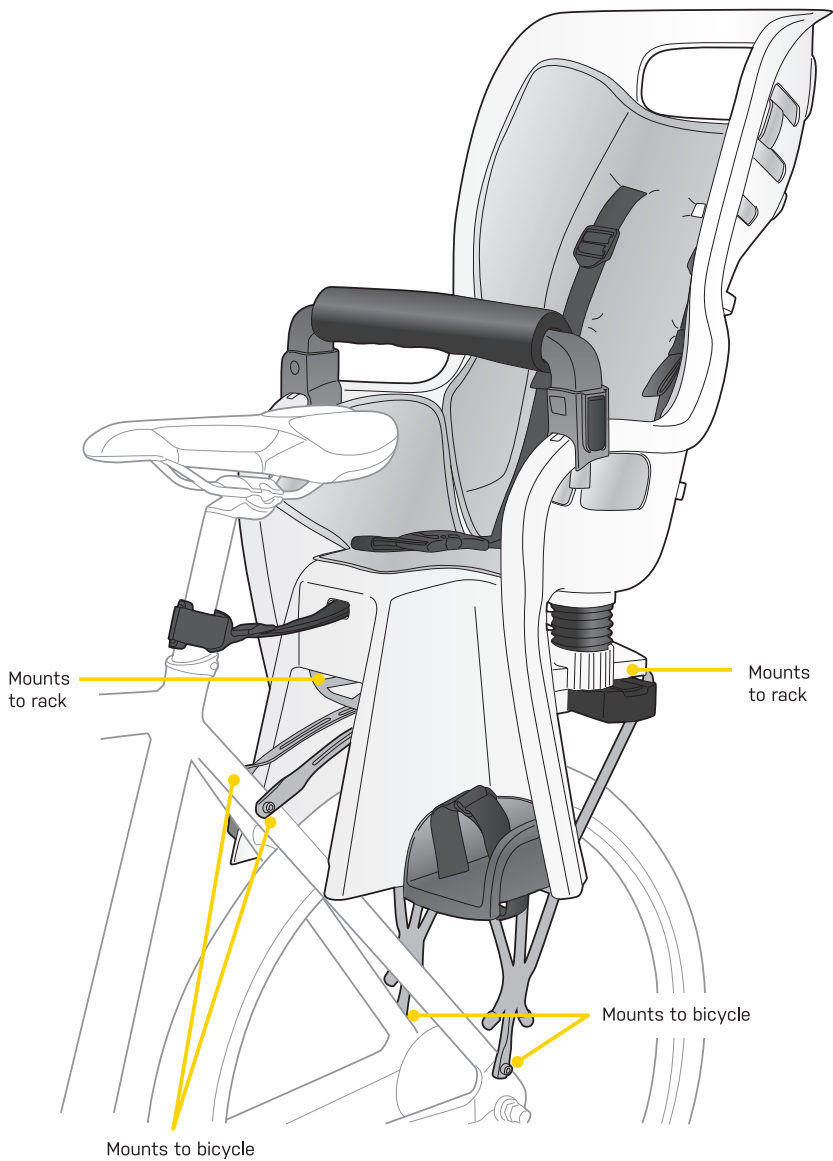

Getting To Know Your Topeak BabySeat

These pages will help you to identify the different parts of your Topeak BabySeat.

ILLUSTRATED PARTS LIST:

- | | |
|--|-----------------------------|
| 1. SEAT | 10. REFLECTOR |
| 2. RACK | 11. SHOCK ABSORBING BASE |
| 3. GRAB BAR | 12. SPRING BARREL x 2 |
| 4. GRAB BAR PAD | 13. SECURING BUCKLE |
| 5. SEAT PAD | 14. BACK LOOP |
| 6. FOOTRESTS x 2 | 15. LOWER HOLE |
| 7. FOOT STRAPS x 2 | 16. BACK HOOK |
| 8. QUICK ADJUST LEVER FOR FOOTRESTS x 2 | 17. REAR SAFETY LIGHT MOUNT |
| 9. SLIDE LOCK WITH BUTTON
(in storage position) | |

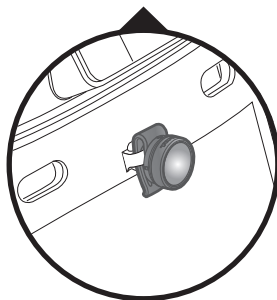

* Rear light not included

MAINTENANCE:

Please use mild soap and water to clean BabySeat, seat pad, safety harness and grab bar pad should be hand washed only. Occasionally lubricate rack and BabySeat hardware with Teflon® based lubricant.

* Teflon® is a registered trademark of DuPont.

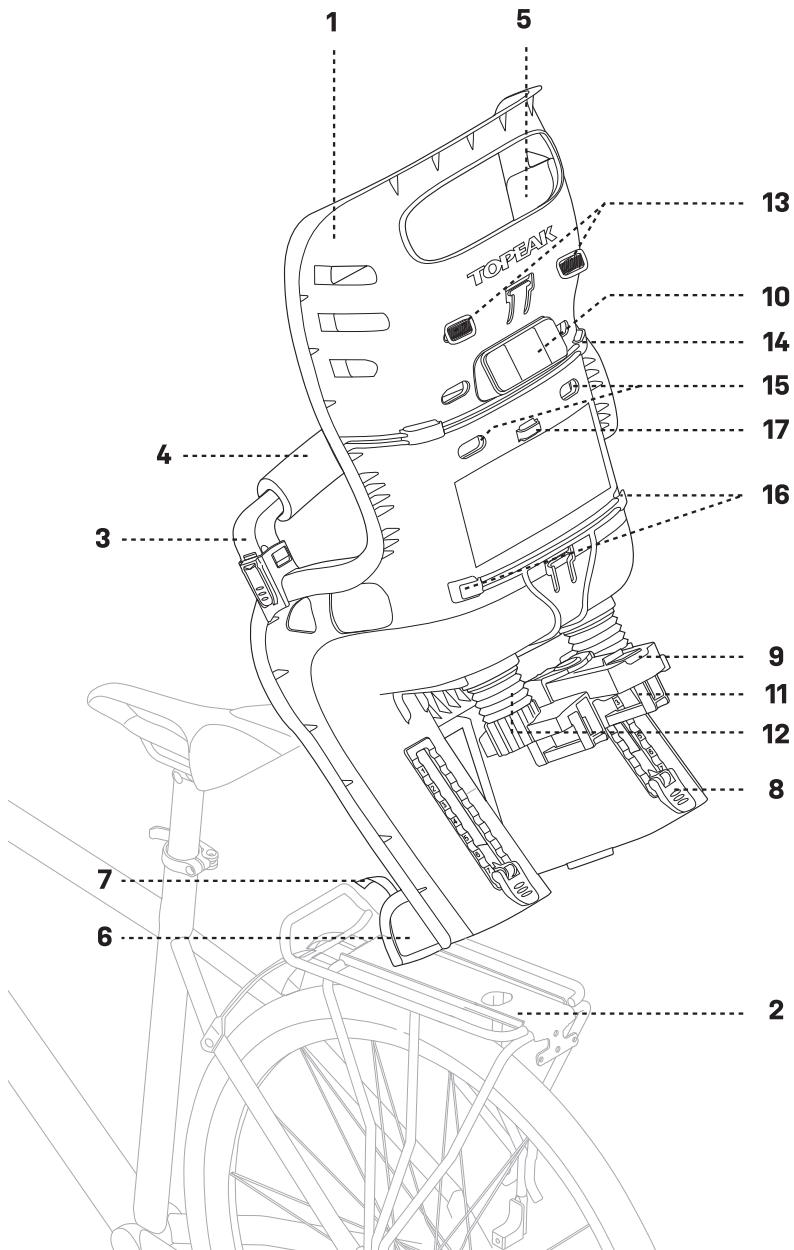

Mounting Rack To Bicycle

Follow these illustrations for mounting rack to bicycle. Make sure rack is level with ground before tightening hardware. Several adjustments are available to help level rack.

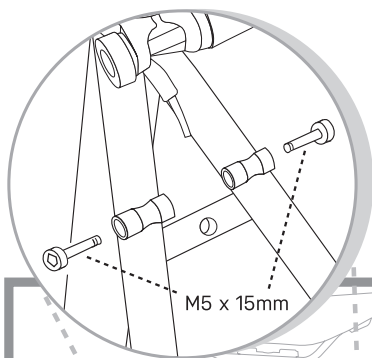

Slide rack hardware forward or back to determine correct positions before tightening Phillips screws on rack surface.

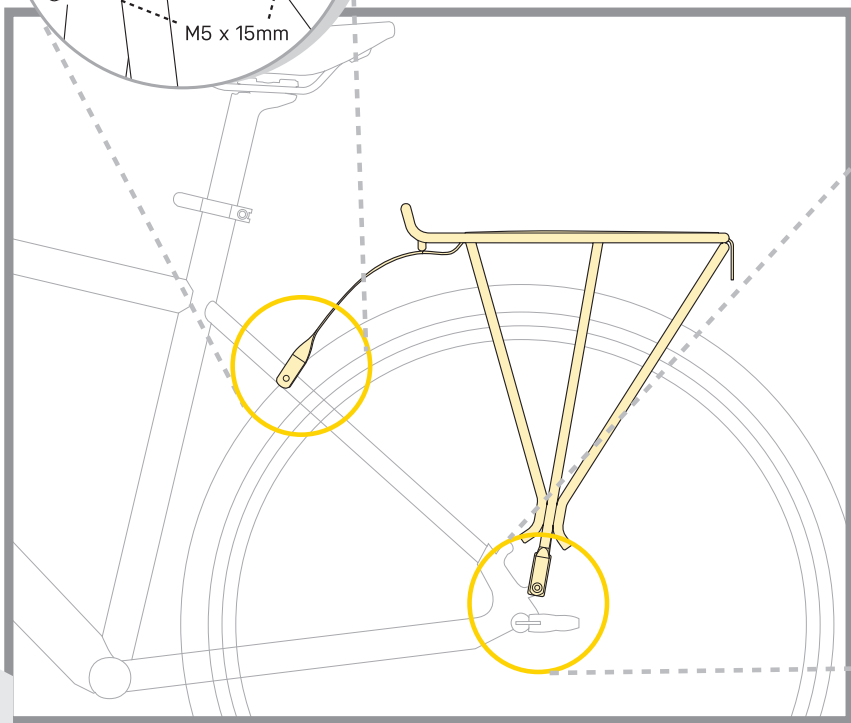

CAUTION

The Topeak BabySeat is designed to work on frames with seatstay rack mounts AND threaded dropout eyelets only. Do not use the Topeak BabySeat on frames without these fittings for safety reasons.

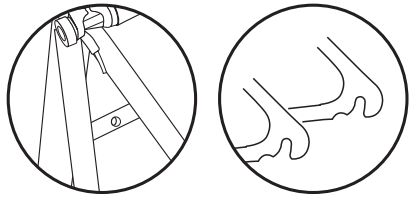

X NO

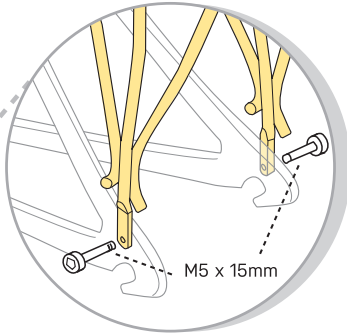

BabySeat Rack w/o disc Mounts

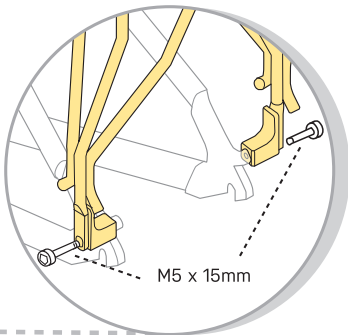

BabySeat Rack w/ disc Mounts

Attach base of rack strut to frame rear dropout. Most frame dropouts provide more than one mounting point.

Mounting BabySeat To Rack Surface

1 Mount BabySeat on rack

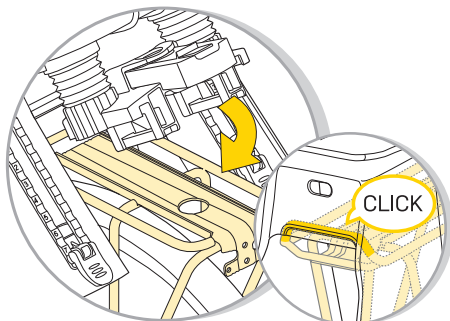

Hook seat onto front rail of rack. Rotate seat down on rack surface until snapped into positive engagement.

2 Remove slide lock from storage position

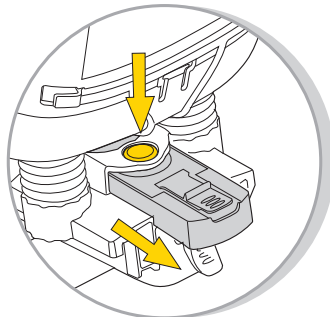

Press the red button and pull the slide lock back away from seat.

3 Install slide lock on rack

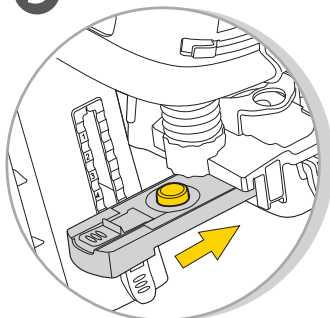

Press red button and push slide lock back into rack.

4

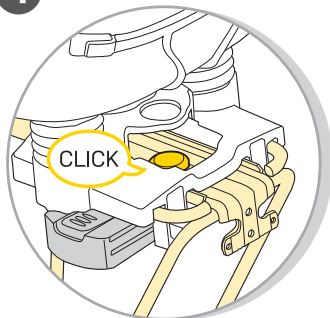

Make sure positive engagement "click" is heard and red button is protruding through hole in rack surface.

CAUTION

- If sliding lock fails to slide into rack or if red button does not protrude through the rack surface the installation is incorrect.
- If your saddle has exposed springs, please cover springs adequately to prevent pinching child passenger.
- Never modify BabySeat or rack from their original specifications.
- Do not attach additional luggage to the child carrier. Recommend to carry such loads at the opposite end of the cycle, e.g. in the case of a rear seat, to use a front luggage carrier.
- Ensure that your bike is stable before installing or removing BabySeat.

Securing BabySeat To SeatPost

"T" type loop and hook strap is a safety device designed to connect BabySeat and seatpost.
Please be sure to fasten it to seatpost immediately after mounting BabySeat on rack. The "T" strap should only be disconnected from seatpost if removing BabySeat from rack.

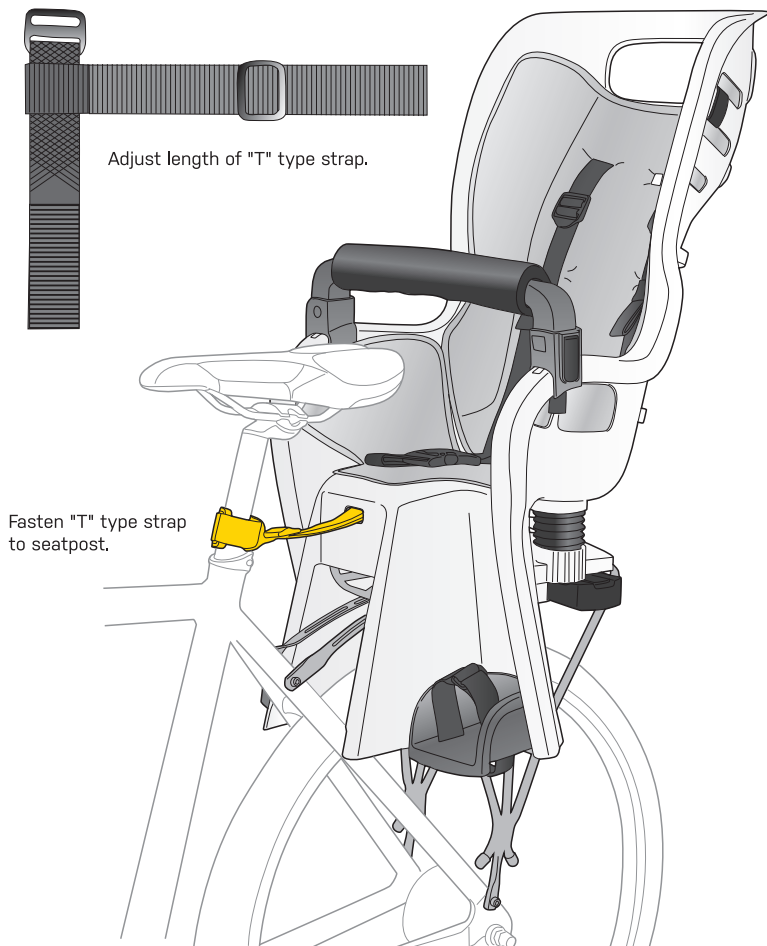

Opening Grab Bar

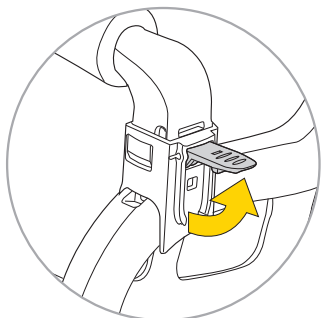

Lift up the lever

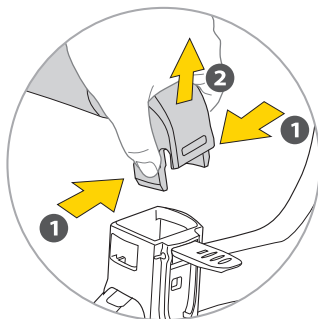

Press tabs and lift to
open grab bar as shown.

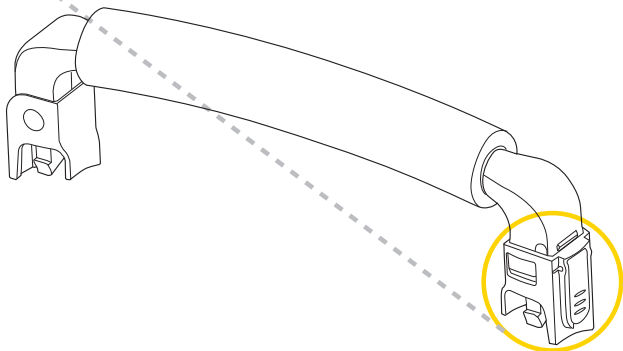

Adjusting Height of Footrests

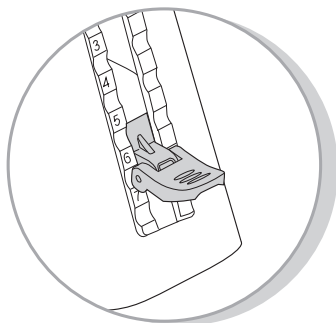

Lift lever to adjust height of footrests.

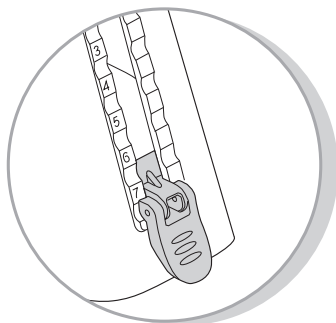

Push lever down to lock.

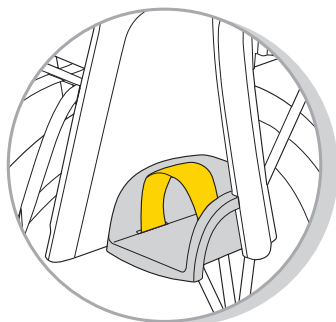

Adjust the foot strap as necessary.



CAUTION

NEVER LEAVE CHILD IN BABYSEAT WITH ONLY THE KICKSTAND SUPPORTING THE BICYCLE.

1. Have someone help support bicycle while placing child in BabySeat.
2. Place child in comfortable position in BabySeat II. Adjust and fasten safety harness over child.
3. Note position of child's feet and legs and tighten the foot straps after placing child in comfortable position. Remove child from BabySeat and adjust footrests as necessary.
4. Don't use the BabySeat if any part is broken.
5. Foot straps may weaken or lose elasticity due to aging, wear, or environmental factors. Users should replace or maintain them as needed.

Fitting Your Child In BabySeat

BabySeat shoulder buckle straps adjust in a high or low position. Make sure they are in the correct position for your child's size.



✓ OK



✗ NO

Shoulder Strap Is Too High.

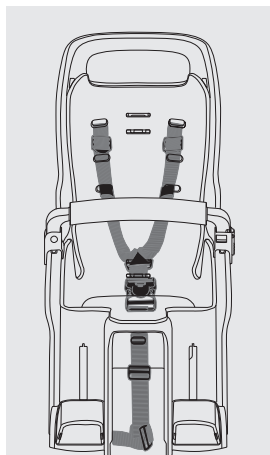

High Position



✓ OK



✗ NO

Shoulder Strap Is Too Low.

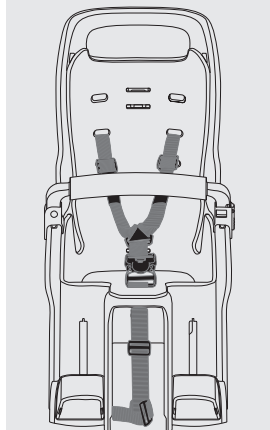

Low Position

! CAUTION

1. Make sure the buckle straps are assembled correctly on the back side of BabySeat as shown above.
2. Ensure the BabySeat harness is correctly installed and securely fastened to prevent the child from escaping.
3. Straps may weaken or lose elasticity due to aging, wear, or environmental factors. Users should replace or maintain them as needed.

Release Seat Pad

- 1** Release the buckle strap from back side.

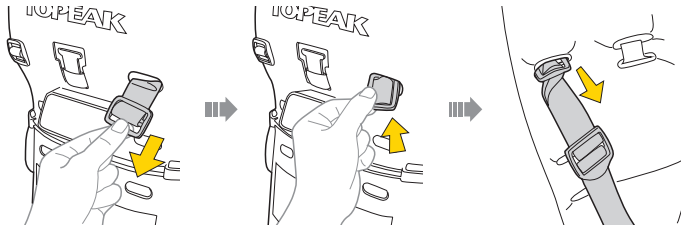

- 2** Remove the fastener on the both sides of BabySeat.

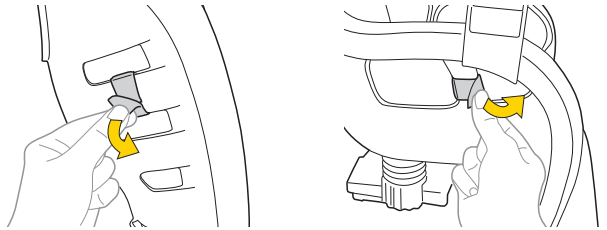

- 3** Release strap on the bottom of seat pad and release the buckle strap.



- 4** Release the buckle strap from back side of seat pad and remove the seat pad from the back hook behind BabySeat.

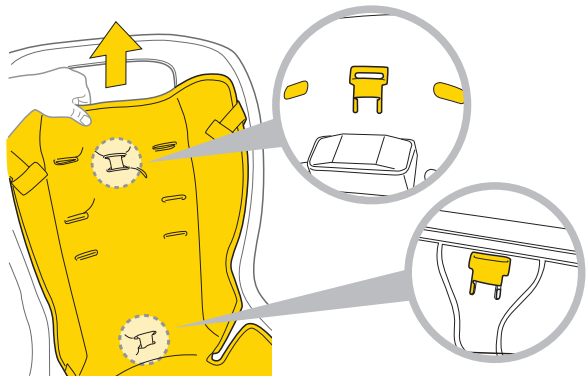



CAUTION



1. Tighten fasteners securely before each use and check them frequently.
2. Do not carry a child who is too young to sit independently in the carrier. (A pediatrician should be consulted before any child younger than one year is carried.)
3. Ensure initially, and check from time to time, that the child's weight does not exceed the load limit of the carrier.
4. Additional luggage or accessories should not be attached to the carrier, as they may exceed the load limit, and may lessen stability. Total load limit for the carrier is **48.5 lb (22 kg)** (For the EU Community, meets EN-14344 Class A22 regulations) / **40 lb (18 kg)** (For USA, meets ASTM F1625 regulations).
5. Make no modifications to the carrier.
6. Do not allow any of the child's body, clothing, shoe laces, or toys to come in contact with moving parts of the bicycle.
7. Always attach the retention system snugly around the child.
8. When no child is being carried, fasten the retention system buckles so the straps do not hang loosely.
9. Ensure the rider and child are wearing approved bicycle helmets.
10. Never ride in inclement weather or hazardous conditions.
11. The load of a child carrier may lessen the stability and alter the riding characteristics of the bicycle, particularly regarding steering and braking.
12. Never leave the child unattended in the carrier.
13. Never leave the child in a carrier with the bicycle supported only by a kickstand.
14. A rear reflector that complies with CPSC regulations must be visible whether the carrier is on the bicycle or not.
15. Before each ride, ensure the mounted carrier does not interfere with braking, pedaling, or steering of the bicycle.
16. Never ride the bicycle at night without adequate lighting.
17. Always remove the carrier from the bicycle when the bicycle is being transported on a motor vehicle. This is necessary because the force of the high wind on the carrier may degrade or damage the carrier to the point that it will not perform reliably.
18. Presence of a child carrier on a bicycle may require alteration of the method used by the rider to mount or dismount the bicycle. Care must be taken whenever the rider gets on or off the bicycle.
19. Bicycle operator's age must be at least 18 years old.
20. Make sure bicycle is stable and under control when loading and unloading child.
21. This baby seat system is not compatible with rear suspension bikes.
22. BabySeat rack is compatible with 26" wheel and 700C wheel bicycles. Optional disc brake compatible rack for 29" wheel is available.
23. The bicycle to which the BabySeat and rack is mounted must be in good working order, of a type appropriate for the additional load, and of proper size and adjustment for the operator. See bicycle owner's manual for additional bicycle loading information. Make sure not to overload your bicycle when using the BabySeat and rack, and make sure not to attach additional luggage or accessories to the rack.
24. The bicycle operator should avoid busy streets, bad weather and ride with extra care and reduced speed.
25. When walking bicycle with child in BabySeat, hold rack with one hand and hold handlebar with the other.
26. Do not carry a child that is too young to sit safely in the seat. Carry only children that are able to sit unaided for a longer period of time.
27. Ensure that the seat does not slope forwards so that the child does not tend to slide out of it, the backrest should slope backwards slightly.

28. Ensure that there are no sharp objects which the child can touch, e.g. frayed cables.
29. Advise that child in BabySeat need to be more warmly clothed than riders and child should be protected from rain.
30. Check any excessive temperature (e.g. due to direct exposure to sun) of the seat before placing the child in it.
31. Cover any exposed rear saddle springs to avoid any possible injury.
32. Ensure that the restraint system is not loose or able to become trapped in any moving parts particularly the wheels, including when the cycle is ridden without a child in the seat.
33. Please connect your nearest Topeak authorized bicycle dealer if you found any broken or damage parts of the babyseat.
34. Straps may weaken or lose elasticity due to aging, wear, or environmental factors. Users should replace or maintain them as needed.

35. The stated distance between the center of gravity mark and front of the rear wheel axis should be less than 100 mm.

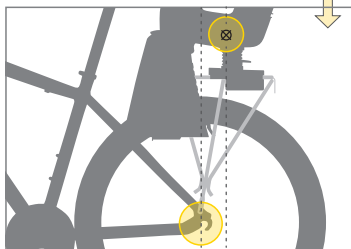

36. For added safety, it's recommended to install a skirt guard (not included) to prevent clothing, accessories, or feet from getting caught in the wheels.

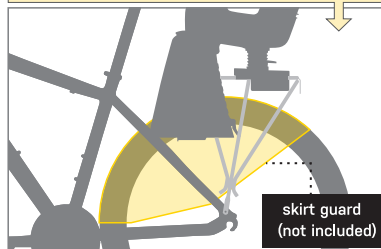

- Failure to comply with the manufacturer's instructions can lead to serious injury or death of the passenger/ rider!
- Do not use the seat if any part is broken.
- Additional security devices shall always be fastened.
- For safety reasons this seat shall only be fitted to luggage carriers conforming to ISO 11243.

The user is responsible for assessing risks and ensuring compliance with safety requirements during installation and use.

WARRANTY

2-year Warranty: All mechanical components against manufacturer defects only.

Warranty Claim Requirements

To obtain warranty service, you must have your original sales receipt. Items returned without a sales receipt will assume that the warranty begins on the date of manufacture. All warranties will be void if the product is damaged due to user crash, abuse, system alteration, modification, or used in any way not intended as described in this operating manual.

* The specifications and design are subject to change without notice.

Please contact your Topeak dealer with any questions.

For USA customer service call: 1-800-250-3068

www.topeak.com

Copyright © Topeak, Inc.

Stamp and signature of Topeak dealer

BABYSEAT II

Remove BabySeat II From Rack

- 1** Press the yellow lever and red button at the same time



- 2** Remove the slide lock then push into storage position



- 3** Lift off BabySeat



Please contact your Topeak dealer with any questions.

For USA customer service call: 1-800-250-3068

www.topeak.com